

Fire Pump Gauge



Application: These gauges are built specifically for use with fire pumps to measure the condition of the pump. Construction is stainless steel case with non-ferrous wetted parts.

Nominal Dial Size:- 63, 80 & 100mm.

Ranges:- -1/+16 bar , -1/+25bar also available dual scale bar/psi

Usually supplied dry, clear oil filled optional

Specification

Mounting:

Flush panel with clamp

Connection Size:

Standard brass 1/4" bsp

Case:

AISI 304 St.St.

Gasket:

polychloroprene or natural white rubber.

Window:

Glass, optional shatterproof acrylic.

Sensing:

Copper Beryllium diaphragms

Movement:

Brass

Dial:

White aluminium, with black markings.

Pointer:

balanced, aluminium

Protection:

IP 65

Datasheet **21FP**

Fire Pump Gauge

63, 80 & 100mm gauges

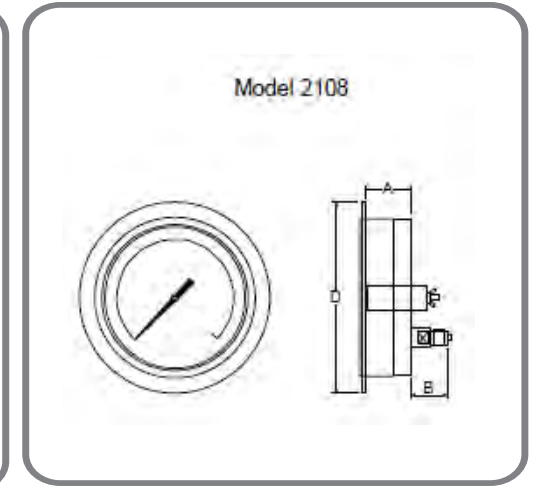
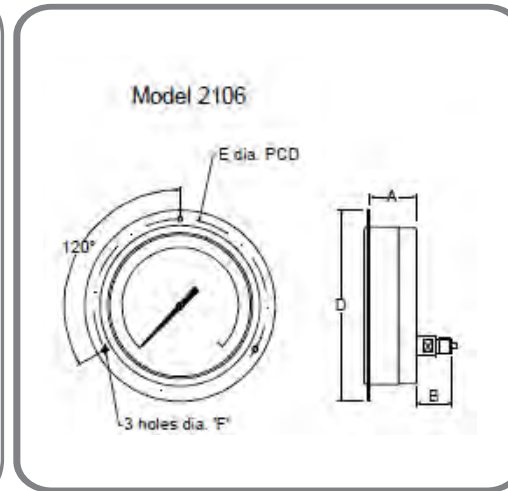
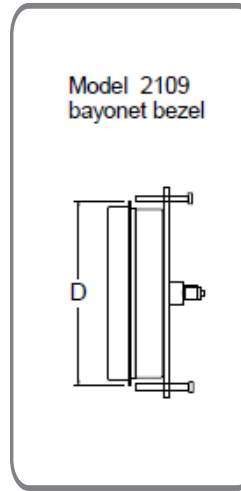
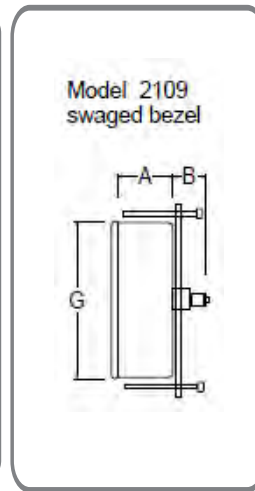
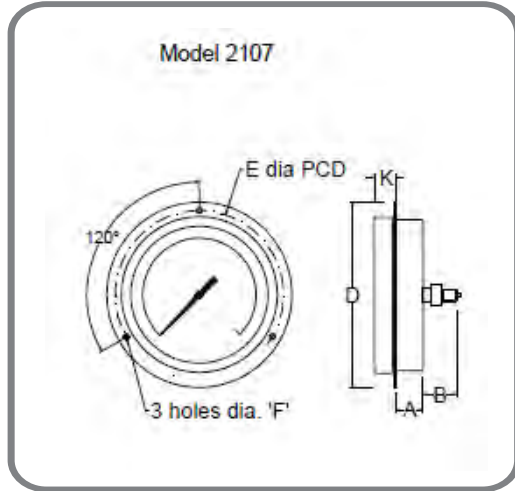

Nominal Diameter	A	B	C	D	E	F	G	K	Panel Cutout
63	30	13	-	70	76	4	70	4/7	62
80	31	30	-	n/a	-	n/a	87	7	81
100	37	27	40	104	116	5.5	104	12	100